



Catellani & Smith®

Gold Moon & Spot Light

lighting cable track system – PSP24-28

chandelier

ISTRUZIONI DI MONTAGGIO / ASSEMBLY INSTRUCTIONS / INSTRUCTIONS DE MONTAGE / MONTAGEANLEITUNGEN / INSTRUCCIONES DE MONTAJE

I AVVERTENZE

- Si raccomanda che l'installazione venga eseguita da un elettricista abilitato.
- Togliere la tensione di alimentazione prima di effettuare l'installazione e per interventi di manutenzione o in caso di cattivo funzionamento.
- Si consiglia l'utilizzo dei guanti in dotazione. Per la pulizia della superficie utilizzare un piumino rimuovi-polvere.
- La lampada acquistata è garantita se installata e utilizzata nel rispetto delle specifiche del modello. Catellani & Smith declina ogni responsabilità per installazione non appropriata e/o uso diverso da quello indicato.
- La sorgente luminosa di questo apparecchio deve essere sostituita esclusivamente dal produttore, dal suo servizio di assistenza o da personale qualificato equivalente.

GB WARNINGS

- Only a qualified electrician should execute the installation.
- Switch off the power supply before installing, servicing or in case of malfunctioning.
- We suggest you to use the gloves provided. We recommend using a feather duster to clean the surfaces.
- The purchased lamp is guaranteed if installed and used in accordance with to the specifications of the model. Catellani & Smith is not responsible for inappropriate installation of the product and/or a different use than the one indicated.
- The lighting source of this appliance must be replaced by the manufacturer, by its technical service or by qualified electrician.

tensione di rete / voltage	<input type="checkbox"/> 220-240V	<input type="checkbox"/> 110V	<input type="checkbox"/> 110-240V
Gold Moon	<input type="text"/>	x 1,1W LED 24Vdc	
Spot Light	<input type="text"/>	x 1,7W LED 24Vdc	
alimentatore / driver	24V constant voltage driver		
dimmerazione / dimming	<input type="checkbox"/> IGBT/Triac	<input type="checkbox"/> 1...10V	<input type="checkbox"/> PUSH <input type="checkbox"/> DALI <input type="checkbox"/> NO

layout n.

quality check n.

I	IP20				
classe class	classe di protezione protection class	persone suggerite per il montaggio people required for mounting		MADE IN ITALY	

UTENSILI NECESSARI PER MONTAGGIO (NON INCLUSI) / TOOLS REQUIRED FOR MOUNTING (NOT SUPPLIED)

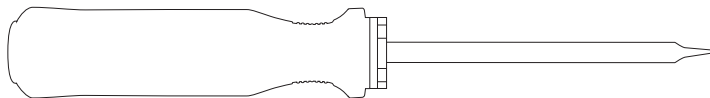

* Per l'installazione munirsi di cacciavite piatto – punta standard

In order to execute the installation, use a flat-head screwdriver – standard

UTENSILI INCLUSI / TOOLS SUPPLIED

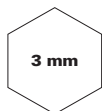

PER RAGIONI DI SICUREZZA, SI CONSIGLIA DI SPELARE IL CAVO PER MAX 7 MM.

FOR SAFETY REASONS WE SUGGEST NOT TO STRIP THE WIRE MORE THAN 7 MM.

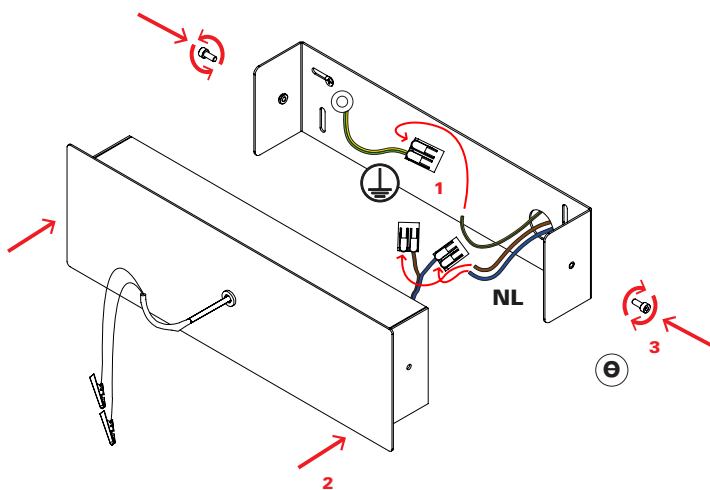
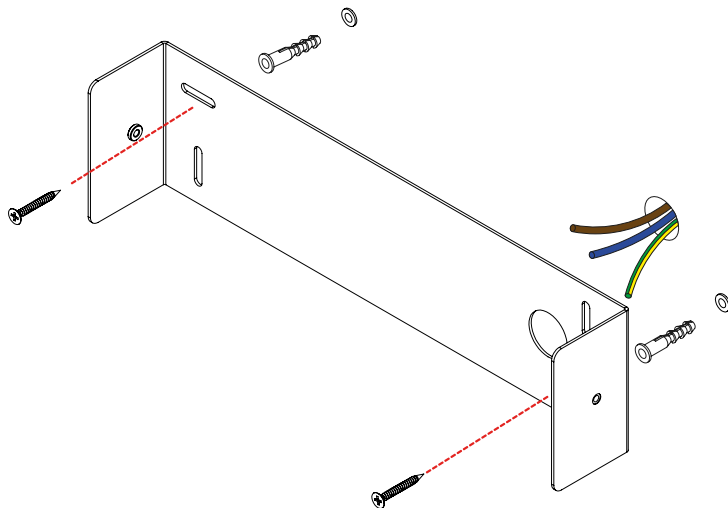
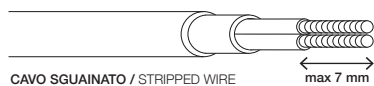

2

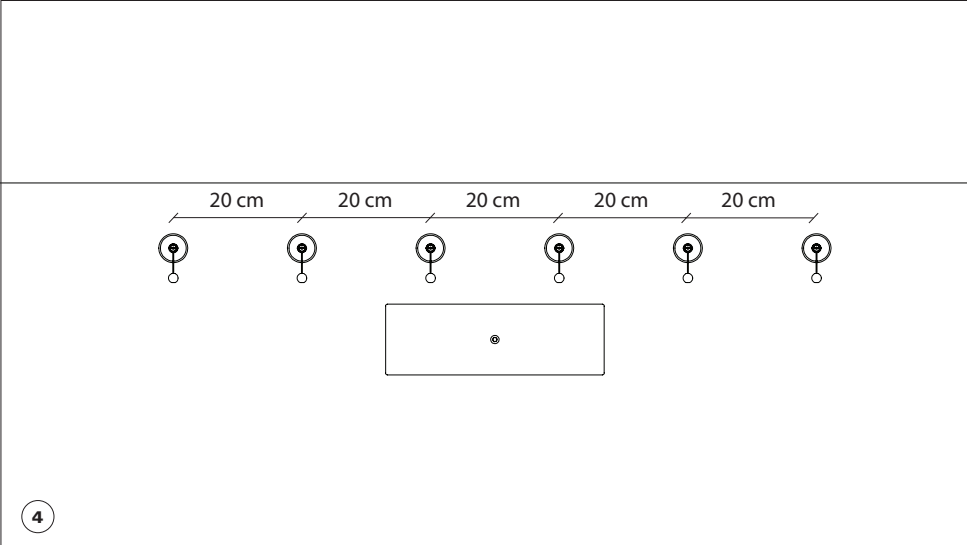
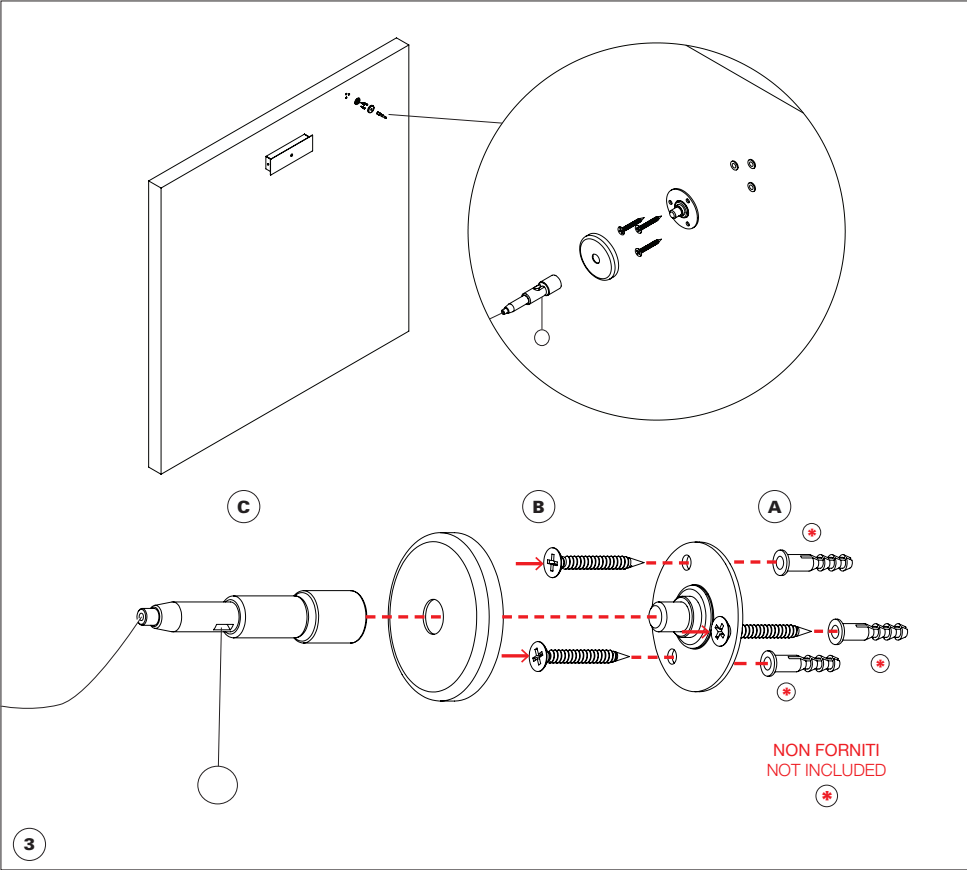

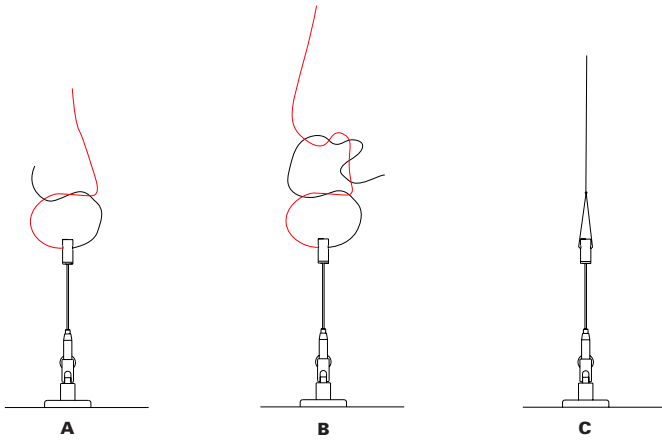

COME ANNODARE IL CAVO
HOW TO KNOT THE CABLE PROPERLY

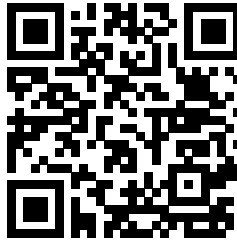

5A

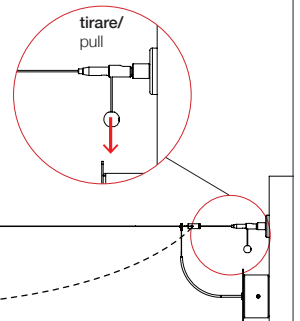

5B

si raccomanda che i dentini della pinzetta a coccodrillo mordano/tocchino il cavo
it is recommended that the teeth of the crocodile clamp bite/touch the wire

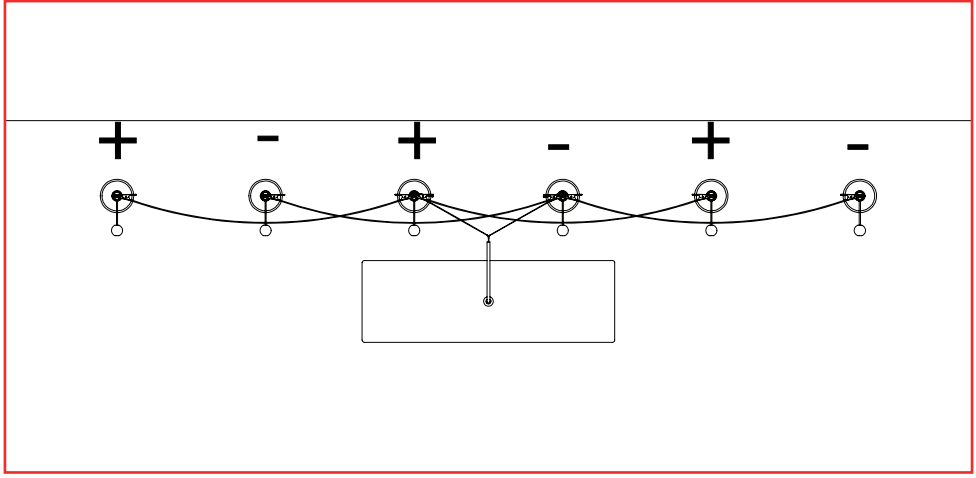
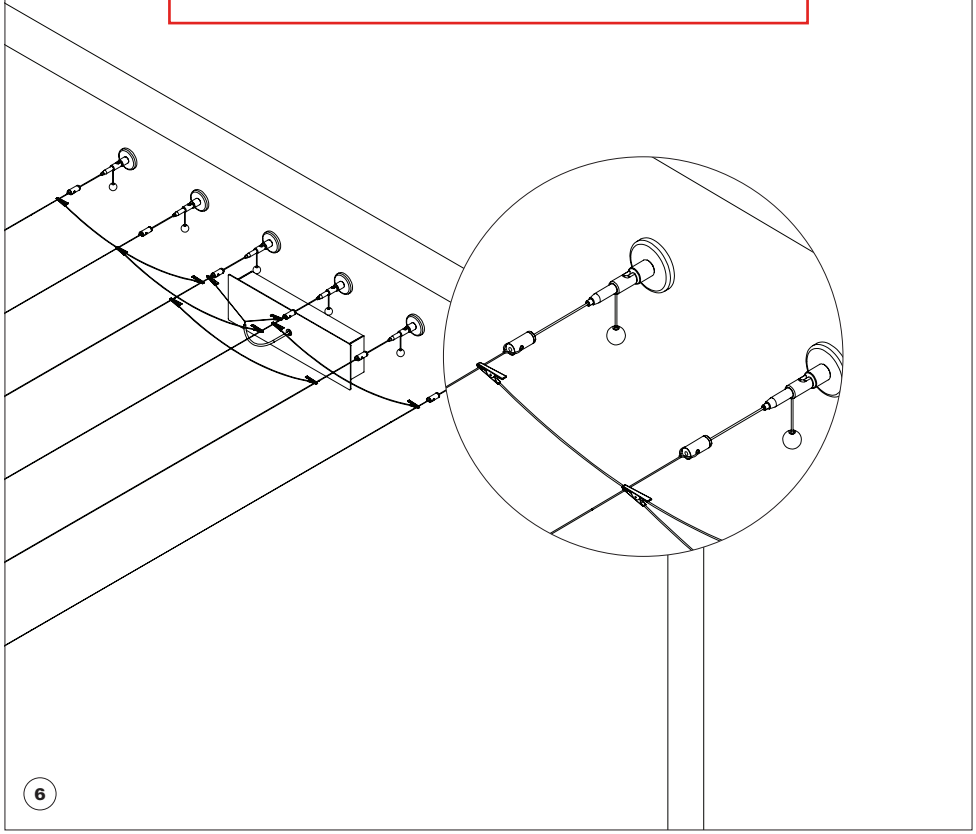

sugeriamo di posizionare i pendenti a sistema cavo alimentato in bassissima tensione 24V, così da verificarne immediatamente il funzionamento
it is suggested to switch on the 24V low voltage power supply before installing each single pendant, in order to check their functioning immediately

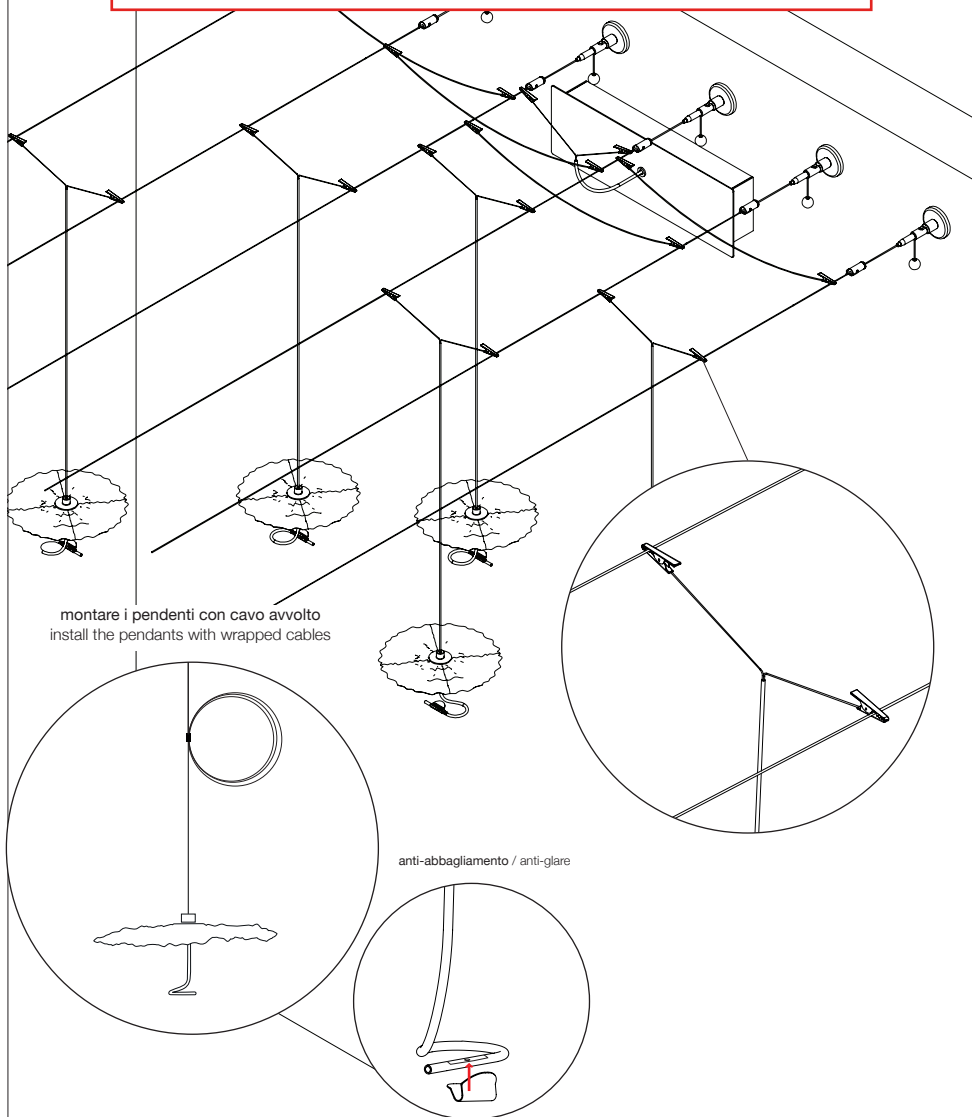

si raccomanda che i dentini della pinzetta a coccodrillo mordano/tocchino il cavo
it is recommended that the teeth of the crocodile clamp bite/touch the wire

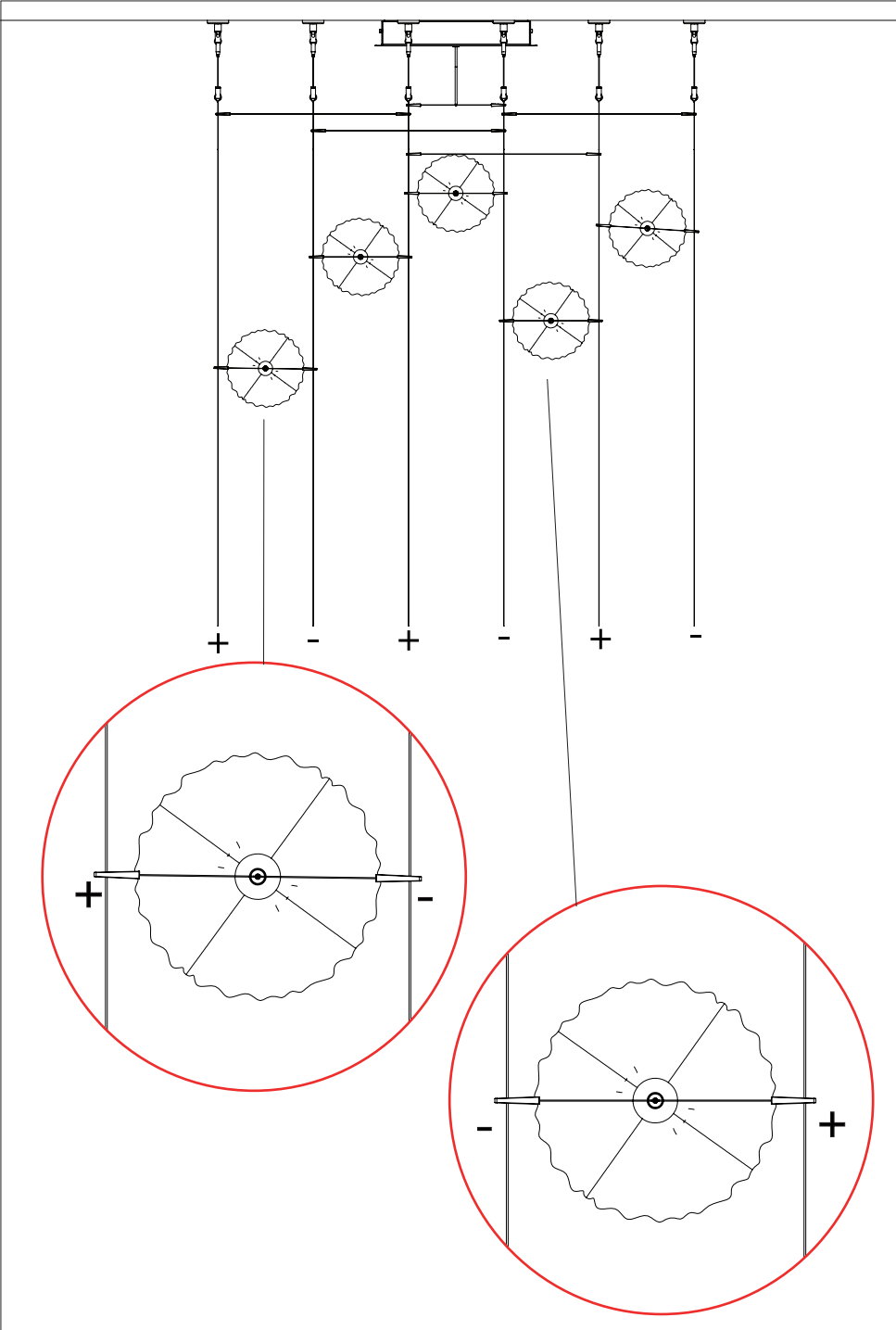

Lo schermo di Gold Moon è in black-wrap, un materiale malleabile: in caso di necessità può quindi essere rimodellato/rimesso in forma con facilità. Si consiglia di effettuare l'operazione prima dell'installazione.

The Gold Moon shade is made of black-wrap, a malleable material, therefore in case of need it can be easily re-shaped. We recommend carrying out this operation before mounting.

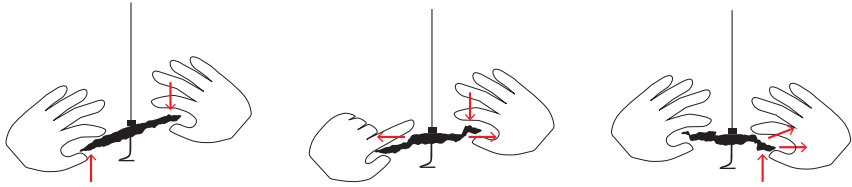

sostituzione LED / LED replacement

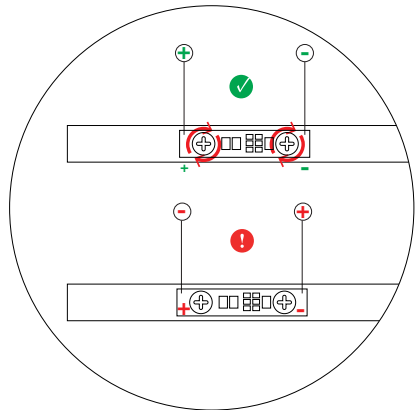
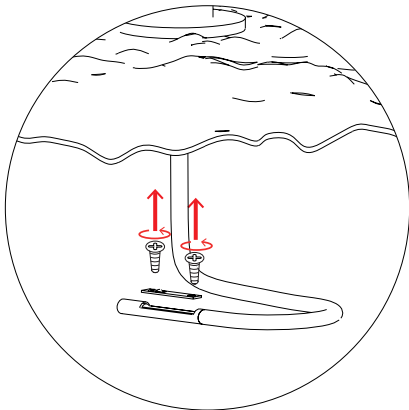

Spot Light

Sostituzione LED
LED replacement

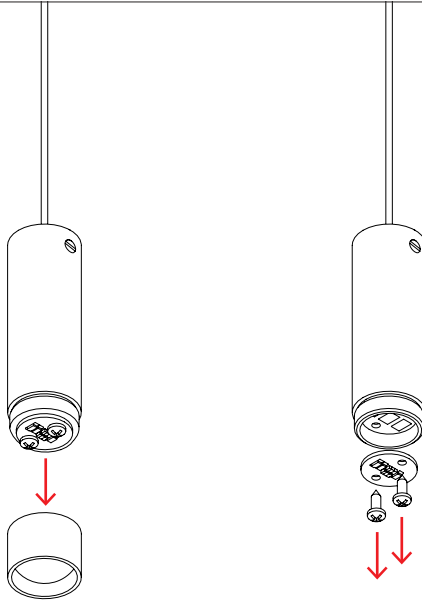



updated 10/2024

Questa apparecchiatura non deve essere smaltita come un normale rifiuto urbano, ma deve essere portata nel punto di raccolta appropriato per il riciclaggio di apparecchiature elettriche ed elettroniche. Provvedendo a smaltire questo prodotto in modo appropriato, si contribuisce ad evitare potenziali conseguenze negative per l'ambiente e per la salute umana, che potrebbero derivare da uno smaltimento inadeguato del prodotto. Per informazioni più dettagliate sul riciclaggio di questo prodotto, contattare l'ufficio comunale, il servizio locale di smaltimento rifiuti o il rivenditore presso il quale è stato acquistato il prodotto.

This equipment may not be treated as household waste. Instead it shall be handed over to the applicable collection point for the recycling of electrical and electronic equipment. By ensuring this product is disposed of correctly, you will help prevent potential negative consequences for the environment and human health, which could otherwise be caused by inappropriate waste handling of this product. For more detailed information about the recycling of this product, please contact your local city office, your household waste disposal or the dealer where you purchased this product.

